

This exam consists of 4 pages. Make sure you have one of each. Print your name at the top of each page now. A fifth page contains a periodic chart, some bond energy data, and some electronegativities. You may tear it off and use it for scratch paper. Show your work on calculations, including unit conversions, and give answers in the correct units and appropriate number of significant figures.

In problems involving molecular and formula weights, you may use values rounded to the nearest 0.1 amu.

If anything confuses you or is not clear, raise your hand and ask!

Page Points

1 _____

2 _____

3 _____

4 _____

Total _____

PLEASE NOTE: The final exam for the course is a block exam, given from 3-5 pm Wednesday, Dec 12. It is not given at the time for 12:20 pm MWF classes.

- (4) 1. Give the symbol for the atoms with the following electron configurations.

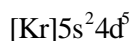
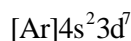
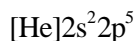
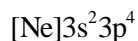

- (4) 2. Give the electron configuration for the following atoms or ions.

Ba

Si

Fe^{+3}

N^{-3}

- (4) 3. Circle the **smallest** and put an **X** through the **largest** atom or ion in each of the following lists.

(a) Li Cr Rb N

(b) K^{+1} Ca^{+2} S^{-2} Cl^{-1}

- (6) 4. For each of the following sets of atoms, circle the atom with the **lowest** ionization energy, and put an **X** through the one with the **largest** ionization energy.

(a) In Al P Cl

(b) K Li Cs Be

(c) O Li Na C

- (4) 5. For each of the following **pairs** of ionic compounds, circle the one with the **greater** lattice energy.

(a) LiF and LiCl (b) MgI_2 and MgF_2

(c) NaCl and $MgCl_2$ (d) NaBr and KBr

- (5) 6. Circle the oxides from the following list which will react with water to form a basic solution:



- (7) 7. For each of the following covalent bonds, put an arrow over the bond indicating the direction of polarity (the arrow pointing to the negative end). If the bond is completely non-polar, so indicate. **Circle** the most polar bond in the list, and **mark with an x** the least polar bond on the list.



- (12) 8. Draw **two** resonance structures for the each of the following molecules or ions, without expanding any octets, and indicate the formal charge on each atom in each structure:

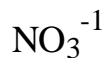

- (16) 9. Calculate ΔH for the following reactions using the table of bond energies on the last page. Show your work. (All reactants and products in the gaseous state).

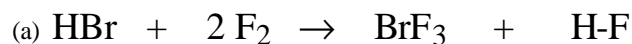

- (16) 10. For each of the following compounds or ions, draw the best Lewis dot structure. (If more than one resonance structure is "best", draw only one). The central atom is underlined. Give the electron pair geometry and the molecular geometry about the central atom.

Compound

Lewis Structureelectron pair
geometrymolecular
geometryCO₂HNO₃

(H attached to O)

PCl₅SeO₂

(8) 11. Draw **three** resonance structures for NCO^{-1} (carbon is the central atom). Calculate the formal charge on each atom in each structure. Circle the structure which you believe is the **best** of the three.

(14) 12. Below is a Born-Haber diagram describing how one can calculate the lattice energy of $\text{NaI}_{(s)}$. Given the following information, fill in the blanks in the diagram with the appropriate energy quantity (showing the correct sign for the arrow direction), then calculate the lattice energy and place that value in the correct blank as well.

Heat of formation of $\text{NaI}_{(s)} = -287.8 \text{ kJ/mol}$
 Ionization energy of $\text{Na}_{(g)} = +496 \text{ kJ/mol}$
 Electron affinity of $\text{I}_{(g)} = -295 \text{ kJ/mol}$
 Bond energy of $\text{I}_{2(g)} = 151 \text{ kJ/mol}$
 Heat of sublimation of $\text{Na}_{(s)} = 107.3 \text{ kJ/mol}$
 Heat of sublimation of $\text{I}_{2(s)} = 62.4 \text{ kJ/mol}$

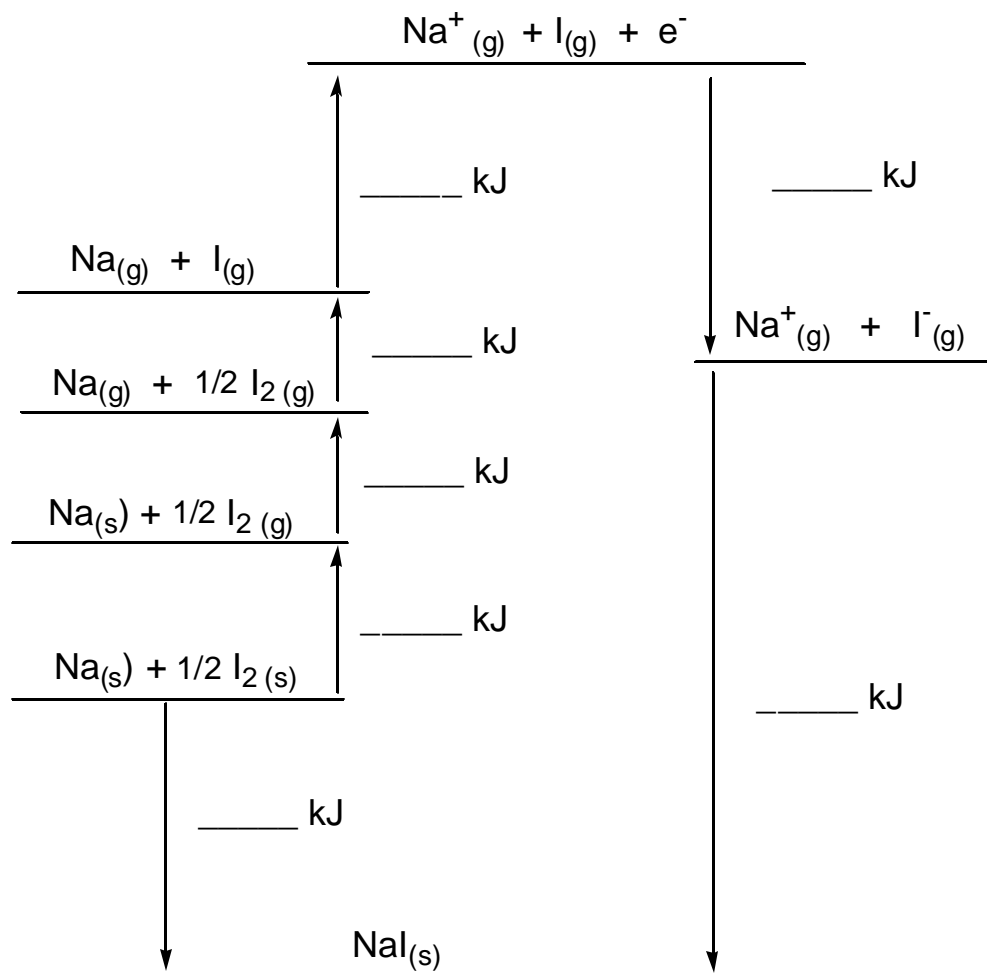

1A 1 H 1.008	2A 3 Li 6.94	4 Be 9.01											3A 5 B 10.81	4A 6 C 12.01	5A 7 N 14.01	6A 8 O 16.00	7A 9 F 19.00	8A 2 He 4.003
11 Na 22.99	12 Mg 24.31	3B	4B	5B	6B	7B	-----	8B	-----	1B	2B	13 Al 26.98	14 Si 28.09	15 P 30.97	16 S 32.06	17 Cl 35.45	18 Ar 39.95	
19 K 39.10	20 Ca 40.08	21 Sc 44.96	22 Ti 47.88	23 V 50.94	24 Cr 52.00	25 Mn 54.94	26 Fe 55.85	27 Co 58.93	28 Ni 58.69	29 Cu 63.55	30 Zn 65.38	31 Ga 69.72	32 Ge 72.59	33 As 74.92	34 Se 78.96	35 Br 79.90	36 Kr 83.80	
37 Rb 85.47	38 Sr 87.62	39 Y 88.91	40 Zr 91.22	41 Nb 92.91	42 Mo 95.94	43 Tc (98)	44 Ru 101.07	45 Rh 102.91	46 Pd 106.4	47 Ag 107.87	48 Cd 112.41	49 In 114.82	50 Sn 118.69	51 Sb 121.75	52 Te 127.60	53 I 126.90	54 Xe 131.29	
55 Cs 132.91	56 Ba 137.33	57 La* 138.91	72 Hf 178.49	73 Ta 180.95	74 W 183.85	75 Re 186.21	76 Os 190.2	77 Ir 192.22	78 Pt 195.08	79 Au 196.97	80 Hg 200.59	81 Tl 204.38	82 Pb 207.2	83 Bi 208.98	84 Po (209)	85 At (210)	86 Rn (222)	
87 Fr (223)	88 Ra 226.03	89 Ac** 227.03	104 Rf (263)	105 Db (262)	106 Sg (266)	107 Bh (264)	108 Hs (269)	109 Mt (268)	110 Uun (272)	111 Uuu	112 Uub	113	114 Uuq	115	116 Uuh	117	118 Uuo	

*Lanthanides

58 Ce 140.12	59 Pr 140.91	60 Nd 144.24	61 Pm (145)	62 Sm 150.36	63 Eu 151.96	64 Gd 157.25	65 Tb 158.93	66 Dy 162.50	67 Ho 164.93	68 Er 167.26	69 Tm 168.93	70 Yb 173.04	71 Lu 174.97
--------------------	--------------------	--------------------	-------------------	--------------------	--------------------	--------------------	--------------------	--------------------	--------------------	--------------------	--------------------	--------------------	--------------------

** Actinides

90 Th 232.04	91 Pa 231.04	92 U 238.03	93 Np 237.05	94 Pu (244)	95 Am (243)	96 Cm (247)	97 Bk (247)	98 Cf (251)	99 Es (254)	100 Fm (257)	101 Md (258)	102 No (259)	103 Lr (262)
--------------------	--------------------	-------------------	--------------------	-------------------	-------------------	-------------------	-------------------	-------------------	-------------------	--------------------	--------------------	--------------------	--------------------

Average Bond Energies (kJ/mol)

Single Bonds:

C-H	413	N-H	391	O-H	463	F-F	155
C-C	348	N-N	163	O-O	146		
C-N	293	N-O	201	O-F	190	Cl-F	253
C-O	358	N-F	272	O-Cl	203	Cl-Cl	242
C-F	485	N-Cl	200	O-I	234		
C-Cl	328	N-Br	243			Br-F	237
C-Br	276			S-H	339	Br-Cl	218
C-I	240	H-H	436	S-F	327	Br-Br	193
C-S	259	H-F	567	S-Cl	253		
		H-Cl	431	S-Br	218	I-Cl	208
Si-H	323	H-Br	366	S-S	266	I-Br	175
Si-Si	226	H-I	299			I-I	151
Si-C	301						
Si-O	368						

Multiple Bonds:

C=C	614	N=N	418	O ₂	495
C≡C	839	N≡N	941		
C=N	615			S=O	523
C≡N	891			S=S	418
C=O	799				
C≡O	1072				

Some Electronegativities

H 2.1	(2A)	(3A)	(4A)	(5A)	(6A)	(7A)
Li 1.0	Be 1.5	B 2.0	C 2.5	N 3.0	O 3.5	F 4.0
Na 0.9	Mg 1.2	Al 1.5	Si 1.8	P 2.1	S 2.5	Cl 3.0
K 0.8	Ca 1.0	Ga 1.6	Ge 1.8	As 2.0	Se 2.4	Br 2.8
[Transition Metals 1.0-2.4]						
Rb 0.8					Te 2.1	I 2.5
Cs 0.7					Po 2.0	At 2.2